

AIPMT - 2012
(Physics, Chemistry and Biology)
Prelims (Code D)

Time: 3 hrs

Total Marks: 800

General Instructions:

1. The Answer sheet is inside this Text booklet. When you are directed to open the text booklet, take out the Answer Sheet and fill in the particulars on side – 1 and side – 2 carefully with blue/black ball point pen only.
 2. The test is of 3 hours duration and consists of 200 questions. Each question carries 3 marks. For each correct response the candidate will get 4 marks. For each incorrect response, one mark will be deducted. The maximum marks are 800.
 3. Use Blue / Black ball point pen only for writing particulars on this page / marking responses.
 4. Rough work is to be done on the space provided for this purpose in the text booklet only.
 5. On completion of the test, the candidate must handover the answer sheet to the invigilator in the room/ Hall. The candidates are allowed to take away this text booklet with them.
 6. Make sure that the CODE printed on side – 2 of the answer sheet is the same as that on this booklet, In case of discrepancy, the candidate should immediately report the matter to the invigilator for the replacement of both the test Booklet and the Answer Sheet.
 7. The candidates should ensure that the Answer sheet is not folded. Do not make any stray marks on the Answer sheet. Do not write your roll no. anywhere else except in the specified space in the Test booklet / Answer Sheet.
 8. Use of white fluid for correction is not permissible on the Answer Sheet.
-

Physics

1. Electron in hydrogen atom first jumps from third excited state to second excited state and then from second excited to the first excited state. The ratio of the wavelength $\lambda_1 : \lambda_2$ emitted in the two cases is
 - (1) 7/5
 - (2) 27/20
 - (3) 27/5
 - (4) 20/7

2. When a string is divided into three segments of length l_1 , l_2 and l_3 the fundamental frequencies of these three segments are ν_1 , ν_2 and ν_3 respectively. The original fundamental frequency (ν) of the string is

(1) $\sqrt{\nu} = \sqrt{\nu_1} + \sqrt{\nu_2} + \sqrt{\nu_3}$

(2) $\nu = \nu_1 + \nu_2 + \nu_3$

(3) $\frac{1}{\nu} = \frac{1}{\nu_1} + \frac{1}{\nu_2} + \frac{1}{\nu_3}$

(4) $\frac{1}{\sqrt{\nu}} = \frac{1}{\sqrt{\nu_1}} + \frac{1}{\sqrt{\nu_2}} + \frac{1}{\sqrt{\nu_3}}$

3. A 200 W sodium street lamp emits yellow light of wavelength $0.6 \mu\text{m}$. Assuming it to be 25% efficient in converting electrical energy to light, the number of photons of yellow light it emits per second is

(1) 1.5×10^{20}

(2) 6×10^{18}

(3) 62×10^{20}

(4) 3×10^{19}

4. Two ideal diodes are connected to a battery as shown in the circuit. The current supplied by the battery is:

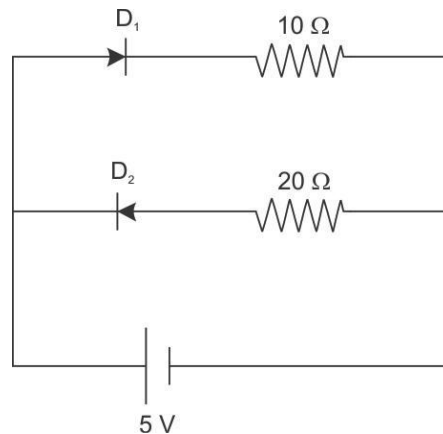

(1) 0.75 A

(2) zero

(3) 0.25 A

(4) 0.5 A

5. When a mass is rotating in a plane about a fixed point, its angular momentum is directed along:

(1) the line perpendicular to the plane of rotation

(2) the line making an angle of 45° to the plane of rotation

(3) the radius

(4) the tangent to the orbit

6. An electric dipole of moment 'p' is placed in an electric field of intensity 'E'. The dipole acquires a position such that the axis of the dipole makes an angle θ with the direction of the field. Assuming that the potential energy of the dipole to be zero when $\theta = 90^\circ$, the torque and the potential energy of the dipole will respectively be:
- (1) $p E \sin\theta, - p E \cos\theta$
 - (2) $p E \sin\theta, - 2 p E \cos\theta$
 - (3) $p E \sin\theta, - 2 p E \cos\theta$
 - (4) $p E \cos\theta, - p E \cos\theta$
7. In a CE transistor amplifier, the audio signal voltage across the collector resistance of $2 \text{ k}\Omega$ is 2 V . If the base resistance is $1 \text{ k}\Omega$ and the current amplification of the transistor is 100, the input signal voltage is:
- (1) 0.1 V
 - (2) 1.0 V
 - (3) 1 mV
 - (4) 10 mV
8. A coil of resistance 400Ω is placed in a magnetic field. If the magnetic flux ϕ (wb) linked with the coil varies with time t (sec) as $\phi = 50t^2 + 4$. The current in the coil at $t = 2 \text{ sec}$ is:
- (1) 0.5 A
 - (2) 0.1 A
 - (3) 2 A
 - (4) 1 A
9. A thermodynamic system is taken through the cycle ABCD as shown in figure. Heat rejected by the gas during the cycle is:

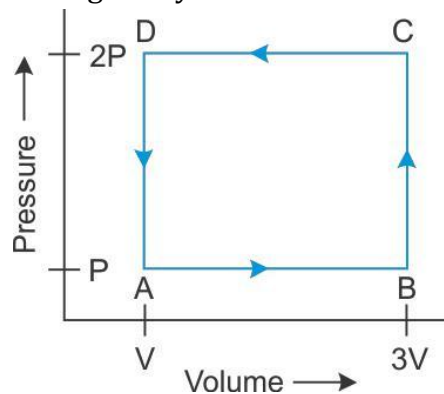

- (1) 2 PV
- (2) 4 PV
- (3) $\frac{1}{2} \text{ PV}$
- (4) PV

10. If the nuclear radius of ^{27}Al is 3.6 fermi, the approximate nuclear radius of ^{64}Cu in fermi is:

- (1) 2.4
- (2) 1.2
- (3) 4.8
- (4) 3.6

11. Two similar coils of radius R are lying concentrically with their planes at right angles to each other. The currents flowing in them are I and $2I$, respectively. The resultant magnetic field induction at the centre will be:

- (1) $\frac{\sqrt{5} \mu_0 I}{2R}$
- (2) $\frac{3\mu_0 I}{2R}$
- (3) $\frac{\mu_0 I}{2R}$
- (4) $\mu_0 R I$

12. The potential energy of particle in a force field is, $U = \frac{A}{r} - \frac{B}{r^2}$

where A and B are positive constants and r is the distance of particle from the centre of the field. For stable equilibrium, the distance of the particle is:

- (1) $B / 2A$
- (2) $2A / B$
- (3) A / B
- (4) B / A

13. When a biconvex lens of glass having refractive index 1.47 is dipped in a liquid, it acts as a plane sheet of glass. This implies that the liquid must have refractive index:

- (1) equal to that of glass
- (2) less than one
- (3) greater than that of glass
- (4) less than that of glass

14. The horizontal range and the maximum height of a projectile are equal. The angle of projection of the projectiles is:

(1) $\theta = \tan^{-1} \left(\frac{1}{4} \right)$

(2) $\theta = \tan^{-1} (4)$

(3) $\theta = \tan^{-1}(2)$

(4) $\theta = 45^\circ$

15. In an electrical circuit R, L, C and an a.c. voltage source are all connected in series.

When L is removed from the circuit, the phase difference between the voltage and the current in the circuit is $\pi/3$. If instead, C is removed from the circuit, the phase difference is again $\pi/3$. The power factor of the circuit is:

(1) $\frac{1}{2}$

(2) $\frac{1}{\sqrt{2}}$

(3) 1

(4) $\frac{\sqrt{3}}{2}$

16. If the radius of a star is R and it acts as a black body, what would be the temperature of the star, in which the rate of energy production is Q?

(1) $Q/4\pi R^2\sigma$

(2) $(Q/4\pi R^2\sigma)^{-1/2}$

(3) $(4\pi R^2Q/\sigma)^{1/4}$

(4) $(Q/4\pi R^2\sigma)^{1/4}$

(σ stands for Stefan's constant)

17. The current (I) in the inductance is varying with time according to the plot shown in figure.

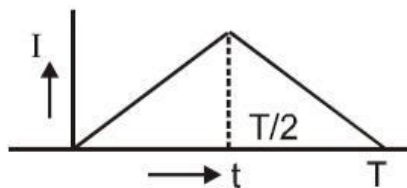

Which one of the following is the correct variation of voltage with time in the coil?

(1)

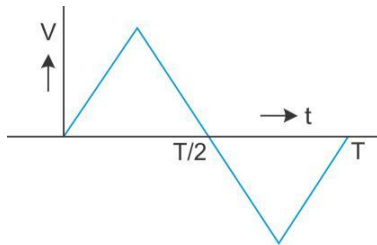

(2)

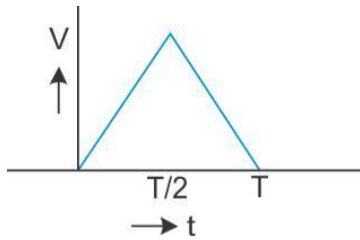

(3)

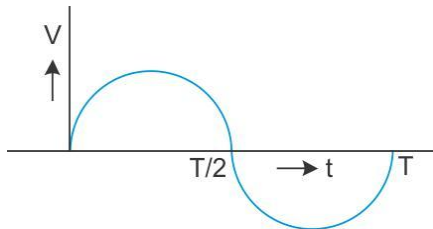

(4)

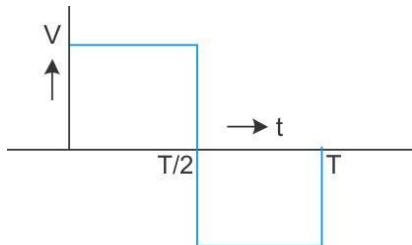

18. A milli voltmeter of 25 milli volt range is to be converted into an ammeter of 25 ampere range. The value (in ohm) of necessary shunt will be:

- (1) 0.001
- (2) 0.01
- (3) 1
- (4) 0.05

19. Two persons of masses 55 kg and 65 kg respectively, are at the opposite ends of a boat. The length of the boat is 3.0 m and weighs 100 kg. The 55 kg man walks up to the 65 kg man and sits with him. If the boat is in still water the centre of mass of the system shifts by:

- (1) 3.0 m
- (2) 2.3 m
- (3) zero
- (4) 0.75 m

20. A mixture consists of two radioactive materials A_1 and A_2 with half lives of 20 s and 10 s respectively. Initially the mixture has 40 g of A_1 and 160 g of A_2 . The amount of the two in the mixture will become equal after:

- (1) 60 s
- (2) 80 s
- (3) 20 s
- (4) 40 s

21. C and Si both have same lattice structure, having 4 bonding electrons in each. However, C is insulator where as Si is intrinsic semiconductor. This is because:

- (1) In case of C the valence band is not completely filled at absolute zero temperature.
- (2) In case of C the conduction band is partly filled even at absolute zero temperature.
- (3) The four bonding electrons in the case of C lie in the second orbit, whereas in the case of Si they lie in the third.
- (4) The four bonding electrons in the case of C lie in the third orbit, whereas for Si they lie in the fourth orbit.

22. The height at which the weight of a body becomes $1/16^{\text{th}}$, its weight on the surface of Earth (radius R), is:

- (1) 5R
- (2) 15R
- (3) 3R
- (4) 4R

23. An electron of a stationary hydrogen atom passes from the fifth energy level to the ground level. The velocity that the atom acquired as a result of photon emission will be:

- (1) $\frac{24hR}{25m}$
- (2) $\frac{25hR}{24m}$
- (3) $\frac{24hR}{25m}$
- (4) $\frac{25hR}{24m}$

(m is the mass of the electron, R is the Rydberg constant and h is the Planck's constant)

24. A compass needle which is allowed to move in a horizontal plane is taken to a geomagnetic pole. It:

- (1) will become rigid showing no movement
- (2) will stay in any position
- (3) will stay in north-south direction only
- (4) will stay in east-west direction only

25. In the circuit shown the cells A and B have negligible resistances. For $V_A = 12\text{ V}$, $R_1 = 500\ \Omega$ and $R = 100\ \Omega$ the galvanometer (G) shows no deflection. The value of V_B is:

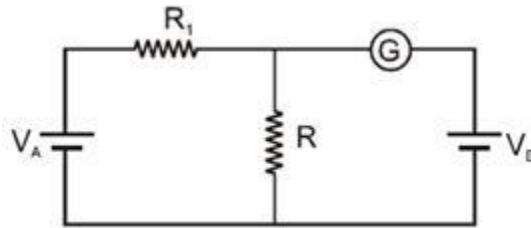

- (1) 4 V
- (2) 2 V
- (3) 12 V
- (4) 6 V

26. Four point charges - Q, -q, 2q and 2Q are placed, one at each corner of the square. The relation between Q and q for which the potential at the centre of the square is zero is:

- (1) $Q = -q$
- (2) $Q = -\frac{1}{q}$
- (3) $Q = q$
- (4) $Q = \frac{1}{q}$

27. A car of mass 1000 kg negotiates a banked curve of radius 90 m on a frictionless road. If the banking angle is 45° , the speed of the car is:

- (1) 20 ms^{-1}
- (2) 30 ms^{-1}
- (3) 5 ms^{-1}
- (4) 10 ms^{-1}

28. A solid cylinder of mass 3 kg is rolling on a horizontal surface with velocity 4 ms^{-1} . It collides with a horizontal spring of force constant 200 Nm^{-1} . The maximum compression produced in the spring will be:

- (1) 0.5 m
- (2) 0.6 m
- (3) 0.7 m
- (4) 0.2 m

29. One mole of an ideal gas goes from an initial state A to final state B via two processes: It first undergoes isothermal expansion from volume V to $3V$ and then its volume is reduced from $3V$ to V at constant pressure. The correct P-V diagram representing the two processes is :

(1)

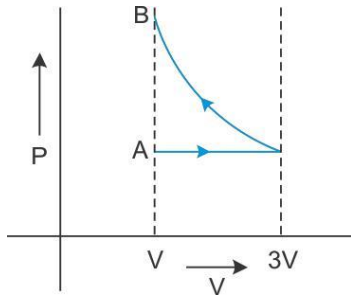

(2)

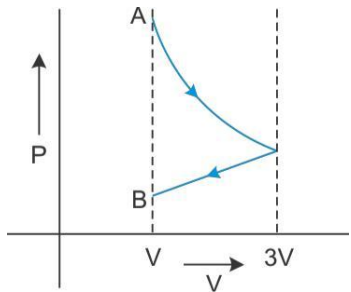

(3)

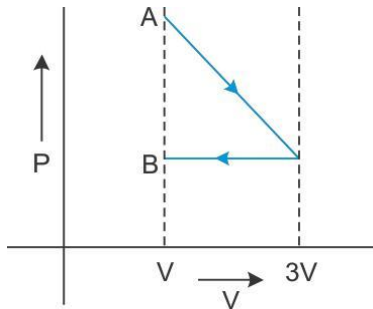

(4)

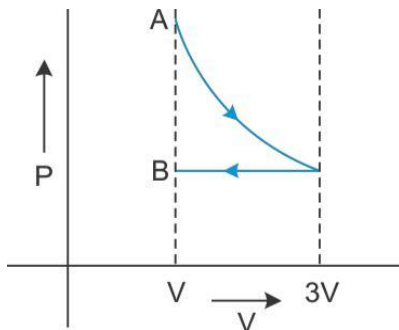

30. Two spheres A and B of masses m_1 and m_2 respectively collide. A is at rest initially and B is moving with velocity v along x-axis. After collision B has a velocity $v/2$ in a direction perpendicular to the original direction. The mass A moves after collision in the direction:

- (1) same as that of B
- (2) Opposite to that of B
- (3) $\theta = \tan^{-1}(1/2)$ to the x-axis
- (4) $\theta = \tan^{-1}(-1/2)$ to the x-axis

31. Liquid oxygen at 50 K is heated to 300 K at constant pressure of 1 atm. The rate of heating is constant. Which one of the following graphs represents the variation of temperature with time?

(1)

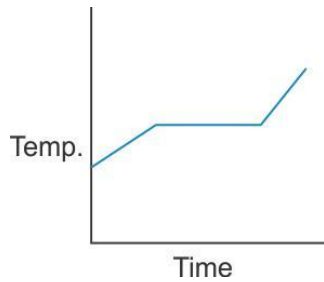

(2)

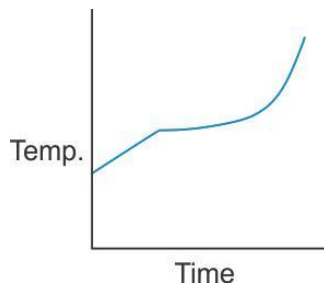

(3)

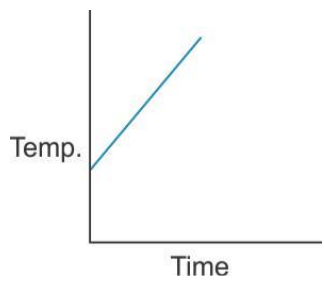

(4)

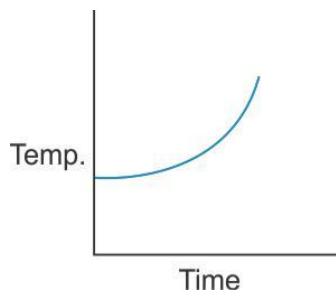

32. An alternating electric field of frequency ν , is applied across the dees (radius = R) of a cyclotron that is being used to accelerate protons (mass = m). The operating magnetic field (B) used in the cyclotron and the kinetic energy (K) of the proton beam produced by it, are given by:

(1) $B = \frac{m\nu}{v^2 R^2 e}$ and $K = 2m\pi^2$

(2) $B = \frac{2\pi m\nu}{\pi\nu R^2 e}$ and $K = m^2$

(3) $B = \frac{2\pi m\nu}{v^2 R^2 e}$ and $K = 2m\pi^2$

(4) $B = \frac{m\nu}{e}$ and $K = m\pi\nu R^2$

33. A spherical planet has a mass M_p and diameter D_p . A particle of mass m falling freely near the surface of this planet will experience an acceleration due to gravity, equal to:

(1) $4GM_p/D_p^2$

(2) $GM_p m/D_p^2$

(3) GM_p/D_p^2

(4) $4GM_p m/D_p^2$

34. A ray of light is incident at an angle of incidence i , on one face of prism of angle A (assumed to be small) and emerges normally from the opposite face. If the refractive index of the prism is μ , the angle of incidence i is nearly equal to:

(1) μA

(2) $\frac{\mu A}{2}$

(3) $\frac{A}{\mu}$

(4) $2^A \mu$

35. The damping force on an oscillator is directly proportional to the velocity. The units of the constant of proportionality are:

(1) Kgms^{-1}

(2) Kgms^{-2}

(3) Kgs^{-1}

(4) kgs

36. A concave mirror of focal length ' f_1 ' is placed at a distance of ' d ' from a convex lens of focal length ' f_2 '. A beam of light coming from infinity and falling on this convex lens - concave mirror combination returns to infinity. The distance ' d ' must equal:

- (1) $f_1 + f_2$
- (2) $-f_1 + f_2$
- (3) $2f_1 + f_2$
- (4) $-2f_1 + f_2$

37. A geostationary satellite is orbiting the Earth at a height of $5R$ above that surface of the Earth, R being the radius of the Earth. The time period of another satellite in hours at a height of $2R$ from the surface of the Earth is:

- (1) 5
- (2) 10
- (3) $6\sqrt{2}$
- (4) $\frac{6}{\sqrt{2}}$

38. Transfer characteristics [output voltage (V_o) vs input voltage (V_i)] for a base biased transistor in CE configuration is as shown in the figure. For using transistor as a switch, it is used:

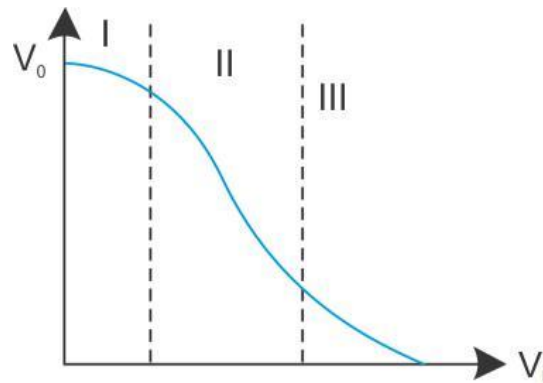

- (1) In region III
- (2) Both in region (I) and (III)
- (3) In region II
- (4) In region I

39. If voltage across a bulb rated 220 volt - 100 watt drops by 2.5% of its rated value, the percentage of the rated value by which the power would decrease is:

- (1) 20%
- (2) 2.5%
- (3) 5%
- (4) 10 %

40. A particle has initial velocity $(2\vec{i} + 3\vec{j})$ and acceleration $(0.3\vec{i} + 0.2\vec{j})$. The magnitude of velocity after 10 seconds will be:

- (1) $9\sqrt{2}$ units
- (2) $5\sqrt{2}$ units
- (3) 5 Units
- (4) 9 Units

41. Monochromatic radiation emitted when electron on hydrogen atom jumps from first excited state to the ground state irradiates a photosensitive material. The stopping potential is measured to be 3.57 V. The threshold frequency of the materials is:

- (1) 4×10^{15} Hz
- (2) 5×10^{15} Hz
- (3) 1.6×10^{15} Hz
- (4) 2.5×10^{15} Hz

42. ABC is an equilateral triangle with O as its centre. \vec{F}_1 , \vec{F}_2 and \vec{F}_3 represents three forces acting along the sides AB, BC and AC respectively. If the total torque about O is zero the magnitude of F_3 is:

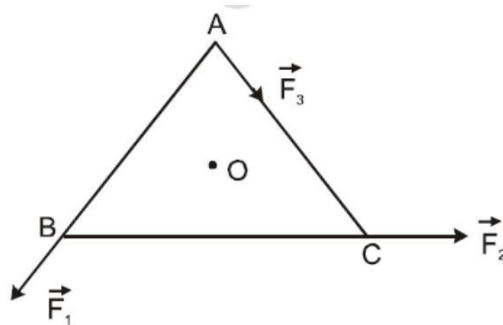

- (1) $F_1 + F_2$
- (2) $F_1 - F_2$
- (3) $\frac{F_1 + F_2}{2}$
- (4) $2(F_1 + F_2)$

43. The figure shows a logic circuit with two inputs A and B and the output C. The voltage wave forms across A, B and C are as given. The logic circuit gate is:

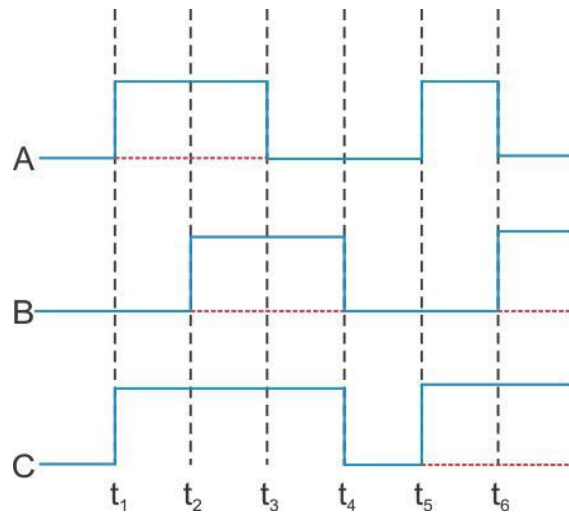

- (1) OR gate
- (2) NOR gate
- (3) AND gate
- (4) NAND gate

44. What is the flux through a cube of side 'a' if a point charge of q is at one of its corner?

- (1) $\frac{2q}{\epsilon_0}$
- (2) $\frac{q}{8\epsilon_0}$
- (3) $\frac{q}{\epsilon_0}$
- (4) $\frac{q}{2\epsilon_0} 6a^2$

45. An α - particle moves in a circular path of radius 0.83 cm in the presence of a magnetic field of 0.25 Wb/m^2 . The de Broglie wavelength associated with the particle will be:

- (1) 1 \AA
- (2) 0.1 \AA
- (3) 10 \AA
- (4) 0.01 \AA

46. The electric field associated with an e.m. wave in vacuum is given by $\vec{E} = \hat{i} \cos (kz - 6 \times 10^8 t)$, where E , z and t are in volt/m, meter and seconds respectively. The value of wave vector k is:
- (1) 2m^{-1}
 - (2) 0.5m^{-1}
 - (3) 36m^{-1}
 - (4) 3m^{-1}
47. The motion of a particle along a straight line is described by equation : $x = 8 + 12t - t^3$ Where x is in metre and t in second. The retardation of the particle when its velocity becomes zero, is:
- (1) 24ms^{-2}
 - (2) Zero
 - (3) 6ms^{-2}
 - (4) 12ms^{-2}
48. The magnifying power of a telescope is 9. When it is adjusted for parallel rays the distance between the objective and eyepiece is 20 cm. The focal length of lenses are:
- (1) 10 cm, 10 cm
 - (2) 15 cm, 5 cm
 - (3) 18 cm, 2 cm
 - (4) 11 cm, 9 cm
49. Two sources of sound placed close to each other are emitting progressive waves given by $y_1 = 4 \sin 600 \pi t$ and $y_2 = 5 \sin 608 \pi t$. An observer located near these two sources of sound will hear:
- (1) 4 beats per second with intensity ratio 25: 16 between waxing and waning.
 - (2) 8 beats per second with intensity ratio 25 : 16 between waxing and waning
 - (3) 8 beats per second with intensity ratio 81 : 1 between waxing and waning
 - (4) 4 beats per second with intensity ratio 81 : 1 between waxing and waning

50. A ring is made of a wire having a resistance $R_0 = 12 \Omega$. Find the points A and B as shown in the figure, at which a current carrying conductor should be connected so that the resistance R of the sub circuit between these points is equal to $\frac{8}{3} \Omega$.

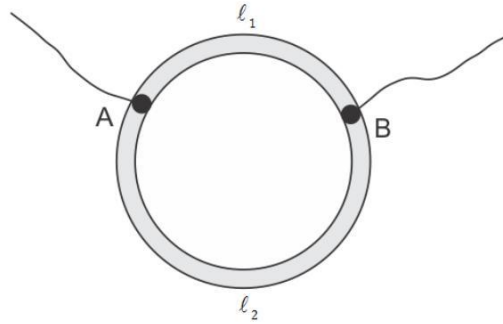

(1) $\frac{l_1}{l} = \frac{5}{8}$

(2) $\frac{l_1^2}{l} = 1$

(3) $\frac{l_1^2}{l} = 3$

(4) $\frac{l_1^2}{l_2} = 1$

Biology

- 51.** Motile zygote of Plasmodium occurs in :
- (1) Gut of female Anopheles
 - (2) Salivary glands of Anopheles
 - (3) Human RBCs
 - (4) Human liver
- 52.** The human hind brain comprises three parts, one of which is :
- (1) Spinal cord
 - (2) Corpus callosum
 - (3) Cerebellum
 - (4) Hypothalamus
- 53.** Which part of the human ear plays no role in hearing as such but is otherwise very much required ?
- (1) Eustachian tube
 - (2) Organ of Corti
 - (3) Vestibular apparatus
 - (4) Ear ossicles
- 54.** The most abundant prokaryotes helpful to humans in making curd from milk and in production of antibiotics are the ones categorised as :
- (1) Cyanobacteria
 - (2) Archaeobacteria
 - (3) Chemosynthetic autotrophs
 - (4) Heterotrophic bacteria
- 55.** Which one of the following statements is false in respect of viability of mammalian sperm?
- (1) Sperm is viable for only up to 24 hours.
 - (2) Survival of sperm depends on the pH of the medium and is more active in alkaline medium.
 - (3) Viability of sperm is determined by its motility.
 - (4) Sperms must be concentrated in a thick suspension
- 56.** Evolution of different species in a given area starting from a point and spreading to other geographical areas is known as :
- (1) Adaptive radiation
 - (2) Natural selection
 - (3) Migration
 - (4) Divergent evolution

57. What is the figure given below showing in particular?

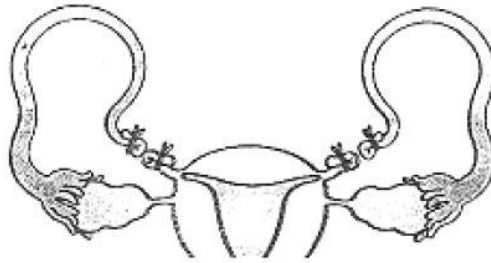

- (1) Ovarian cancer
- (2) Uterine cancer
- (3) Tubectomy
- (4) Vasectomy

58. In an area where DDT had been used extensively, the population of birds declined significantly because:

- (1) birds stopped laying eggs
- (2) earthy worms in the area got eradicated
- (3) cobras were feeding exclusively on birds
- (4) many of the birds laid, did not hatch

59. The figure below is the diagrammatic representation of the E.Coli vector pBR 322. Which one of the given options correctly identifies its certain component (s)?

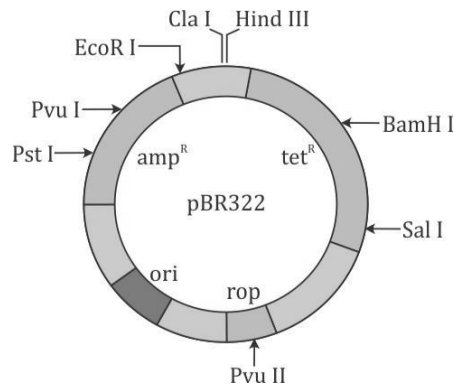

- (1) ori - original restriction enzyme
- (2) rop-reduced osmotic pressure
- (3) Hind III, EcoRI - selectable markers
- (4) ampR, tetR - antibiotic resistance genes

60. The common bottle cork is a product of :

- (1) Dermatogen
- (2) Phellogen
- (3) Xylem
- (4) Vascular Cambium

61. Widal Test is carried out to test :

- (1) Malaria
- (2) Diabetes mellitus
- (3) HIV/AIDS
- (4) Typhoid fever

62. Which part would be most suitable for raising virus-free plants for micropropagation?

- (1) Bark
- (2) Vascular tissue
- (3) Meristem
- (4) Node

63. Which one of the following is a wrong statement ?

- (1) Most of the forests have been lost in tropical areas.
- (2) Ozone in upper part of atmosphere is harmful to animals.
- (3) Greenhouse effect is a natural phenomenon.
- (4) Eutrophication is a natural phenomenon in freshwater bodies.

64. Companion cells are closely associated with :

- (1) Sieve elements
- (2) Vessel elements
- (3) Trichomes
- (4) Guard cells

65. Common cold differs from pneumonia in, that :

- (1) Pneumonia is a communicable disease whereas the common cold is a nutritional deficiency disease.
- (2) Pneumonia can be prevented by a live attenuated bacterial vaccine whereas the common cold has no effective vaccine.
- (3) Pneumonia is caused by a virus while the common cold is caused by the bacterium *Haemophilus influenzae*.
- (4) Pneumonia pathogen infects alveoli whereas the common cold affects nose and respiratory passage but not the lungs.

66. Pheretima and its close relatives derive nourishment from :

- (1) sugarcane roots
- (2) decaying fallen leaves and soil organic matter.
- (3) soil insects
- (4) small pieces of fresh fallen leaves of maize, etc.

67. Removal of RNA polymerase III from nucleoplasm will affect the synthesis of :

- (1) t RNA
- (2) hn RNA
- (3) m RNA
- (4) r RNA

68. A process that makes important difference between C3 and C4 plants is :

- (1) Transpiration
- (2) Glycolysis
- (3) Photosynthesis
- (4) Photorespiration

69. PCR and Restriction Fragment Length Polymorphism are the methods for :

- (1) Study of enzymes
- (2) Genetic transformation
- (3) DNA sequencing
- (4) Genetic Fingerprinting

70. Best defined function of Manganese in green plants is :

- (1) Photolysis of water
- (2) Calvin cycle
- (3) Nitrogen fixation
- (4) Water absorption

71. Measuring Biochemical Oxygen Demand (BOD) is a method used for :

- (1) estimating the amount of organic matter in sewage water.
- (2) working out the efficiency of oil driven automobile engines.
- (3) measuring the activity of *Saccharomyces cerevisiae* in producing curd on a commercial scale.
- (4) working out the efficiency of R.B.Cs. about their capacity to carry oxygen

72. Which one -of the following is not a part of a transcription unit in DNA ?

- (1) The inducer
- (2) Aterminator
- (3) Apromoter
- (4) The structural gene

- 73.** A certain road accident patient with unknown blood group needs immediate blood transfusion. His one doctor friend at once offers his blood. What was the blood group of the donor?
- (1) Blood group B
 - (2) Blood group AB
 - (3) Blood group O
 - (4) Blood group A
- 74.** Consumption of which one of the following foods can prevent the kind of blindness associated with vitamin 'A' deficiency?
- (1) Flaver Savr' tomato
 - (2) Canolla
 - (3) Golden rice
 - (4) Bt-Brinjal
- 75.** The maximum amount of electrolytes and water (70 - 80 percent) from the glomerular filtrate is reabsorbed in which part of the nephron?
- (1) Ascending limb of loop of Henle
 - (2) Distal convoluted tubule
 - (3) Proximal convoluted tubule
 - (4) Descending limb of loop of Henle
- 76.** Both, autogamy and geitonogamy are prevented in -
- (1) Papaya
 - (2) Cucumber
 - (3) Castor
 - (4) Maize
- 77.** Placentation in tomato and lemon is
- (1) Parietal
 - (2) Free central
 - (3) Marginal
 - (4) Axile

78. A person entering an empty room suddenly finds a snake right in front on opening the door. Which one of the following is likely to happen in his neuro-hormonal control system?

- (1) Sympathetic nervous system is activated releasing epinephrin and norepinephrin from adrenalmedulla.
- (2) Neurotransmitters diffuse rapidly across the cleft and transmit a nerve impulse.
- (3) Hypothalamus activates the parasympathetic division of brain.
- (4) Sympathetic nervous system is activated releasing epinephrin and norepinephrin from adrenal cortex.

79. Which one of the following is not a gaseous biogeochemical cycle in ecosystem ?

- (1) Sulphur cycle
- (2) Phosphorus cycle
- (3) Nitrogen cycle
- (4) Carbon cycle

80. A single strand of nucleic acid tagged with a radioactive molecule is called :

- (1) Vector
- (2) Selectable marker
- (3) Plasmid
- (4) Probe

81. Which one of the following options gives one correct example each of convergent evolution and divergent evolution?

	Convergent evolution		Divergent evolution
(1)	Eyes of octopus and mammals		Bones of forelimbs of vertebrates
(2)	Thorns of Bougainvillia and tendrils of Cucurbita		Wings of butterflies and birds
(3)	Bones of forelimbs of vertebrates		Wings of butterfly and birds
(4)	Thorns of Bougainvillia and tendrils Cucurbita		Eyes of Octopus and mammals

82. An organic substance that can withstand environmental extremes and cannot be degraded by any enzyme is :

- (1) Cuticle
- (2) Sporopollenin
- (3) Lignin
- (4) Cellulose

83. Cycas and Adiantum resemble each other in having:

- (1) Seeds
- (2) Motile Sperms
- (3) Cambium
- (4) Vessels

84. What was the most significant trend in the evolution of modern man (Homo sapiens) from his ancestors?

- (1) Shortening of jaws
- (2) Binocular vision
- (3) Increasing cranial capacity
- (4) Upright posture

85. Cymose inflorescence is present in :

- (1) Solanurn
- (2) Sesbania
- (3) Trifolium
- (4) Brassica

86. Ribosomal RNA is actively synthesized in

- (1) Lysosomes
- (2) Nucleolus
- (3) Nucleoplasm
- (4) Ribosomes

87. During gamete formation, the enzyme recombinase participates during

- (1) Metaphase - I
- (2) Anaphase - II
- (3) Prophase - I
- (4) Prophase - II

88. Identify the possible link "A" in the following food chain :

Plant → insect → frog → "A" → Eagle

- (1) Rabbit
- (2) Wolf
- (3) Cobra
- (4) Parrot

89. Phyllode is present in :

- (1) Asparagus
- (2) Euphorbia
- (3) Australian Acacia
- (4) Opuntia

90. Given below is an imaginary pyramid of numbers. What could be one of the possibilities about certain organisms at some of the different levels?

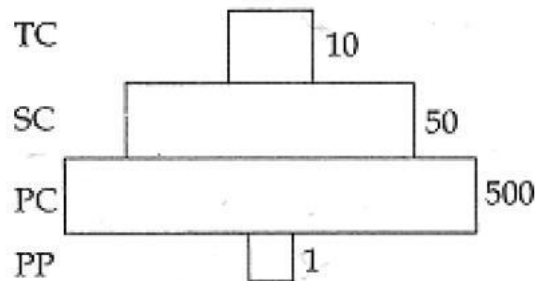

- (1) Level PC is "insects" and level SC is "small insectivorous birds".
- (2) Level PP is "phytoplanktons" in sea and "Whale" on top level TC
- (3) Level one PP is "pipal trees" and the level SC is "sheep".
- (4) Level PC is "rats" and level SC is "cats".

91. *Monascus purpureus* is a yeast used commercially in the production of :

- (1) ethanol
- (2) streptokinase for removing clots from the blood vessels.
- (3) Citric acid
- (4) blood cholesterol lowering statins

92. The correct sequence of cell organelles during photorespiration is :

- (1) Chloroplast, -Golgi bodies, -mitochondria
- (2) Chloroplast, -Rough Endoplasmic reticulum, Dictyosomes
- (3) Chloroplast, -mitochondria, -peroxisome
- (4) Chloroplast, -vacuole, -peroxisome

93. Which one of the following is correctly matched ?

- (1) Passive transport of nutrients - ATP
- (2) Apoplast - Plasmodesmata
- (3) Potassium - Readily immobilisation
- (4) Bakane of rice seedlings - F. Skoog

- 94.** A normal- visioned man whose father was colour- blind, marries a woman whose father was also colour- blind. They have their first child as a daughter. what are the chance that this child would be colour- blind ?
- (1) 100%
 - (2) zero percent
 - (3) 25%
 - (4) 50 %
- 95.** Signals for parturition originate from :
- (1) Both placenta as well as fully developed foetus
 - (2) Oxytocin released from maternal pituitary
 - (3) Placenta only
 - (4) Fully developed foetus only
- 96.** A patient brought to a hospital with myocardial infarction is normally immediately given :
- (1) Penicillin
 - (2) Streptokinase
 - (3) Cyclosporin-A
 - (4) Statins
- 97.** Which one of the following is not a property of cancerous cells whereas the remaining three are?
- (1) They compete with normal cells for vital nutrients.
 - (2) They do not remain confined in the area of formation.
 - (3) They divide in an uncontrolled manner
 - (4) They show contact inhibition.
- 98.** The gynoecium consists of many free pistils in flowers of
- (1) Aloe
 - (2) Tomato
 - (3) Papaver
 - (4) Michelia
- 99.** Which one of the following is not a functional unit of an ecosystem
- (1) Energy flow
 - (2) Decomposition
 - (3) Productivity
 - (4) Stratification

100. In a normal pregnant woman, the amount of total gonadotropin activity was assessed. The result expected was

- (1) High level of circulating FSH and LH in the uterus to stimulate implantation of the embryo
- (2) High level of circulating HCG to stimulate endometrial thickening
- (3) High level of FSH and LH in uterus to stimulate endometrial thickening
- (4) High level of circulating HCG to stimulate estrogen and progesterone synthesis

101. Which one of the following areas in India, is a hotspot of biodiversity

- (1) Eastern Ghats
- (2) Gangetic Plain
- (3) Sunderbans
- (4) Western Ghats

102. Which one of the following is a correct statement

- (1) Pteridophyte gametophyte has a protonemal and leafy stage
- (2) In gymnosperms female gametophyte is free-living
- (3) Antheridiophores and archegoniophores are present in pteridophytes.
- (4) Origin of seed habit can be traced in pteridophytes

103. Which one of the following does not differ in E.coli and Chlamydomonas

- (1) Ribosomes
- (2) Chromosomal Organization
- (3) Cell wall
- (4) Cell membrane

104. The cyanobacteria are also referred to as

- (1) prokaryotes
- (2) golden algae
- (3) Slime moulds
- (4) blue green algae

105. The test-tube Baby Programme employs which one of the following techniques

- (1) Intra cytoplasmic sperm injection (ICSI)
- (2) Intra uterine insemination (IUI)
- (3) Gamete intra fallopian transfer (GIET)
- (4) Zygote intra fallopian transfer (ZIFT)

106. Which one of the following is a case of wrong matching

- (1) Somatic hybridization - Fusion of two diverse cells
- (2) Vector DNA -Site for t-RNA synthesis.
- (3) Micropropagation - In vitro production of plants in large numbers.
- (4) Callus - Unorganised mass of cell produced in tissue culture

107. The highest number of species in the world is represented by

- (1) Fungi
- (2) Mosses
- (3) Algae
- (4) Lichens

108. In which one of the following options the two examples are correctly matched with their particular type of immunity

	Examples	Type of immunity
(1)	Polymorphonuclear leukocytes and mono cytes	Cellular barriers
(2)	Anti-tetanus and anti – snake bite injection	Active immunity
(3)	Saliva in mouth and Tears in eyes	Physical barriers
(4)	Mucus coating of epithelium lining the urnogenital tract and the HCl in stomach	Pysiological barriers

109. Which one of the following is wrong statement

- (1) Anabaena and Nostoc are capable of fixing nitrogen in free living state also.
- (2) Root nodule forming nitrogen fixers live as aerobes under free-living conditions.
- (3) Phosphorus is a constituent of cell membranes, certain nucleic acids and cell proteins.
- (4) Nitrosomonas ans Nitrobacter are chemoautotrophs.

110. Anxiety and eating spicy food together in an otherwise normal human, may lead to

- (1) Indigestion
- (2) Jaundice
- (3) Diarrhoea
- (4) Vomiting

111. The Leydig cells found in the human body are the secretory source of

- (1) Progesterone
- (2) intestinal mucus
- (3) glucagon
- (4) androgens

112. Compared to those of humans, the erythrocytes in frog are

- (1) Without nucleus but with haemoglobin
- (2) nucleated and with haemoglobin
- (3) very much smaller and fewer
- (4) nucleated and without haemoglobin.

113. In which one of the following the genus name, its two characters and its phylum are not correctly matched, whereas the remaining three are correct

	Genus name		Two Characters	Phylum
(1)	Pila	(a)	Body Semented	Mollusca
		(b)	Mouth with Radual	
(2)	Asterias	(a)	Spiny skinned	Echinoermata
		(b)	Water vascular system	
(3)	Sycon	(a)	Pore bearing	Porifera
		(b)	Canal system	
(4)	Periplaneta	(a)	Jointed appendages	Arthropoda
		(b)	Chitinous exoskeleton	

114. What is true about ribosomes

- (1) The prokaryotic ribosomes are 80S, where "S" stands for sedimentation coefficient
- (2) These are composed of ribonucleic acid and proteins
- (3) These are found only in eukaryotic cells
- (4) These are self-splicing introns of some RNAs.

115. Cirrhosis of liver is caused by the chronic intake of

- (1) Opium
- (2) Alcohol
- (3) Tobacco (Chewing)
- (4) Cocaine

116. Which one is a true statement regarding DNA polymerase used in PCR

- (1) It is used to ligate introduced DNA in recipient cell
- (2) It serves as a selectable marker
- (3) It is isolated from a virus
- (4) It remains active at high temperature

117. Which statement is wrong for viruses

- (1) All are parasites
- (2) All of them have helical symmetry
- (3) They have ability of synthesize nucleic acids and proteins
- (4) (4)Antibiotics have no effect on them

118. Which one of the following is correctly matched

- (1) Onion - Bulb
- (2) Ginger - Sucker
- (3) Chlamydomonas - Conidia
- (4) Yeast - Zoospores

119. How many plants in the list given below have composite fruits that develop from an inflorescence

Walnut, poppy, radish, fig, pineapple, apple, tomato, mulberry

- (1) Four
- (2) Five
- (3) Two
- (4) Three

120. Given below is the diagrammatic representation of one of the categories of small molecular weight organic compounds in the living tissues. Identify the category shown and the one blank component "X" in it.

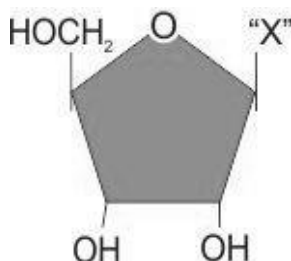

- | | Category | Component |
|-----|-------------|-----------------|
| (1) | Cholesterol | Guanin |
| (2) | Amino acid | NH ₂ |
| (3) | Nucleotide | Adenine |
| (4) | Nucleoside | Uracil |

- 121.** Which one of the following microbes forms symbiotic association with plants and helps them in their nutrition?
- (1) Azotobacter
 - (2) Aspergillus
 - (3) Glomus
 - (4) Trichoderma
- 122.** The extinct human who lived 1,00,000 to 40,000 years ago, in Europe, Asia and parts of Africa, with short stature, heavy eyebrows, retreating fore haeds, large jaws with heavy teeth, stocky bodies, a lumbering gait and stooped posture was
- (1) Hamo habilis
 - (2) Neanderthal human
 - (3) Cro-magnan humans
 - (4) Ramapithecus
- 123.** If one strand of DNA has the nitrogenous base sequence at ATCTG, what would be the complementary RNA strand sequence
- (1) TTAGU
 - (2) UAGAC
 - (3) AACTG
 - (4) ATCGU
- 124.** Which one of the following pairs of hormones are the examples of those that can easily pass through the cell membrane of the target cell and bind to a receptor inside it (Mostly in the nucleus)
- (1) Insulin, glucagon
 - (2) Thyroxin, insulin
 - (3) Somatostain, oxytocin
 - (4) Cortisol, testosterone
- 125.** Nuclear mebrane is absent in
- (1) Penicillium
 - (2) Agaricus
 - (3) Volvox
 - (4) Nostoc
- 126.** Which one is the most abundant protein in the animal world
- (1) Trypsin
 - (2) Hemoglobin
 - (3) Collagen
 - (4) Insulin

127. Which one of the following is common to multicellular fungi, filamentous algae and protonema of mosses

- (1) Diplontic life cycle
- (2) Members of kingdom plantae
- (3) Mode of Nutrition
- (4) Multiplication by fragmentation

128. Which one single organism or the pair of organisms is correctly assigned to its or their named taxonomic group

- (1) Paramecium and Plasmodium belong to the same kingdom as that of Penicillium
- (2) Lichen is a composite organism formed from the symbiotic association of an algae and a protozoan
- (3) yeast used in making bread and beer is a fungus
- (4) Nostoc and Anabaena are examples of protista

129. Even in absence of pollinating agents seed setting is assured in

- (1) Commellina
- (2) Zostera
- (3) Salvia
- (4) Fig

130. Yeast is used in the production of

- (1) Citric acid and lactic acid
- (2) Lipase and pectinase
- (3) Bread and beer
- (4) Cheese and butter

131. Which one out of A-D given below correctly represents the structural formula of the basic amino acid

A	B	C	D
$ \begin{array}{c} \text{NH}_2 \\ \\ \text{H} - \text{C} - \text{COOH} \\ \\ \text{CH}_2 \\ \\ \text{CH}_2 \\ \\ \text{C} \\ // \quad \backslash \\ \text{O} \quad \text{OH} \end{array} $	$ \begin{array}{c} \text{NH}_2 \\ \\ \text{H} - \text{C} - \text{COOH} \\ \\ \text{CH}_2 \\ \\ \text{OH} \end{array} $	$ \begin{array}{c} \text{CH}_2\text{OH} \\ \\ \text{CH}_2 \\ \\ \text{CH}_2 \\ \\ \text{NH}_2 \end{array} $	$ \begin{array}{c} \text{NH}_2 \\ \\ \text{H} - \text{C} - \text{COOH} \\ \\ \text{CH}_2 \\ \\ \text{CH}_2 \\ \\ \text{CH}_2 \\ \\ \text{NH}_2 \end{array} $

- (1) C
- (2) D
- (3) A
- (4) B

132. The upright pyramid of number is absent in

- (1) Pond
- (2) Forest
- (3) Lake
- (4) Grassland

133. What is correct to say about the hormone action in humans

- (1) Glucagon is secreted by β cells of Islets of Langerhans and stimulates glycogenolysis
- (2) Secretion of thymosins is stimulated with aging
- (3) In females FSH first binds with specific receptors on ovarian cell membrane
- (4) FSH stimulates the secretion of estrogen and progesterone

134. Closed vascular bundles lack

- (1) Ground tissue
- (2) conjunctive tissue
- (3) Cambium
- (4) Pith

135. Which one of the following is the correct statement for respiration in human

- (1) Cigarette smoking may lead of inflammation of bronchi
- (2) Neural signals from pneumotaxic centre in pons region of brain can increase the duration of inspiration
- (3) Workers in grinding and stone - breaking industries may suffer, from lung fibrosis
- (4) About 90% of carbon dioxide (CO₂) is carried by haemoglobin as carbamino haemoglobin

136. Removal of introns and joining of exons in a defined order during transcription is called :

- (1) Looping
- (2) Inducing
- (3) Slicing
- (4) Splicing

- 137.** F₂ generation in a Mendelian cross showed that both genotypic and phenotypic ratios are same as 1: 2: 1. It represents a case of:
- (1) Co-dominance
 - (2) Dihybrid cross
 - (3) Monohybrid cross with complete dominance
 - (4) Monohybrid cross with incomplete dominance

- 138.** Given below is the representation of a certain event at a particular stage of a type of cell division. Which is this stage?

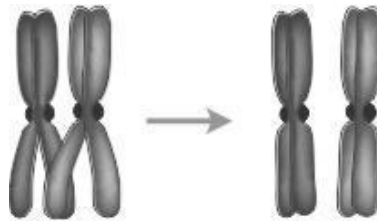

- (1) Prophase I during meiosis
 - (2) Prophase II during meiosis
 - (3) Prophase of Mitosis
 - (4) Both prophase and metaphase of mitosis
- 139.** People who have migrated from the plains to an area adjoining Rohatang Pass about six months back :
- (1) havemore RBCs and their haemoglobin has a lower binding affinity to O₂.
 - (2) are not physically fit to play games like football.
 - (3) suffer from altitude sickness with symptoms like nausea, fatigue, etc.
 - (4) have the usual RBC count but their haemoglobin has very high binding affinity to O₂.
- 140.** For transformation, micro-particles coated with DNA to be bombarded with gene gun are made up of :
- (1) Silver or Platinum
 - (2) Platinum or Zinc
 - (3) Silicon or Platinum
 - (4) Gold or Tungsten
- 141.** A nitrogen-fixing microbe associated with Azolla in rice fields is :
- (1) Spirulina
 - (2) Anabaena
 - (3) Frankia
 - (4) Tolypothrix

142. Select the correct statement regarding the specific disorder of muscular or skeletal system :-

- (1) Muscular dystrophy - age related shortening of muscles.
- (2) Osteoporosis - decrease in bone mass and higher chance of fractures with advancing age.
- (3) Myasthenia gravis - Auto immune disorder which inhibits sliding of myosin filaments
- (4) Gout - inflammation of joints due to extra deposition of calcium.

143. Water containing cavities in vascular bundles are found in :

- (1) Sunflower
- (2) Maize
- (3) Cycas
- (4) Pinus

144. Select the correct statement from the following regarding cell membrane.

- (1) Na⁺ and K⁺ ions move across cell membrane by passive transport
- (2) Proteins make up 60 to 70% of the cell membrane.
- (3) Lipids are arranged in a bilayer with polar heads towards the inner part.
- (4) Fluid mosaic model of cell membrane was proposed by Singer and Nicolson

145. Gymnosperms are also called soft wood spermatophytes because they lack :

- (1) Cambium
- (2) Phloem fibres
- (3) Thick-walled tracheids
- (4) Xylem fibres

146. The coconut water and the edible part of coconut are equivalent to :

- (1) Endosperm
- (2) Endocarp
- (3) Mesocarp
- (4) Embryo

147. Vexillary aestivation is characteristic of the family

- (1) Fabaceae
- (2) Asteraceae
- (3) Solanaceae
- (4) Brassicaceae

148. Which one of the following is an example of carrying out biological control of pests/diseases using microbes ?

- (1) Trichoderma sp. against certain plant pathogens
- (2) Nucleopolyhedrovirus against white rust in Brassica
- (3) Bt - cotton to increase cotton yield
- (4) Lady bird beetle against aphids in mustard

149. Select the correct statement from the ones given below with respect to *Periplaneta americana*.

- (1) Nervous system located dorsally, consists of segmentally arranged ganglia joined by a pair of longitudinal connectives.
- (2) Males bear a pair of short thread like anal styles.
- (3) There are 16 very long Malpighian tubules present at the junctions of midgut and hindgut.
- (4) Grinding of food is carried out only by the mouth parts.

150. Maximum nutritional diversity is found in the group.

- (1) Fungi
- (2) Animalia
- (3) Monera
- (4) Plantae

Chemistry

151. Aluminium is extracted from alumina (Al_2O_3) by electrolysis of a molten mixture of:

- (1) $\text{Al}_2\text{O}_3 + \text{HF} + \text{NaAlF}_4$
- (2) $\text{Al}_2\text{O}_3 + \text{CaF}_2 + \text{NaAlF}_4$
- (3) $\text{Al}_2\text{O}_3 + \text{Na}_3\text{AlF}_6 + \text{CaF}_2$
- (4) $\text{Al}_2\text{O}_3 + \text{KF} + \text{Na}_3\text{AlF}_6$

152. pH of a saturated solution of $\text{Ba}(\text{OH})_2$ is 12. The value of solubility product (K_{sp}) of $\text{Ba}(\text{OH})_2$ is :

- (1) 3.3×10^{-7}
- (2) 5.0×10^{-7}
- (3) 4.0×10^{-6}
- (4) 5.0×10^{-6}

153. When Cl_2 gas reacts with hot and concentrated sodium hydroxide solution, the oxidation number of chlorine changes from :

- (1) Zero to +1 and zero to -5
- (2) Zero to -1 and zero to +5
- (3) Zero to -1 and zero to +3
- (4) Zero to +1 and zero to -3

154. Maximum number of electrons in a subshell with : $l = 3$ and $n = 4$ is :

- (1) 14
- (2) 16
- (3) 10
- (4) 12

155. Which one of the following is an outer orbital complex and exhibits paramagnetic behaviour?

- (1) $[\text{Ni}(\text{NH}_3)_6]^{2+}$
- (2) $[\text{Zn}(\text{NH}_3)_6]^{2+}$
- (3) $[\text{Cr}(\text{NH}_3)_6]^{3+}$
- (4) $[\text{Co}(\text{NH}_3)_6]^{3+}$

156. In a reaction, $\text{A} + \text{B} \rightarrow \text{Product}$, rate is doubled when the concentration of B is doubled, and rate increases by a factor of 8 when the concentrations of both the reactants (A and B) are doubled, rate law for the reaction can be written as :

- (1) $\text{Rate} = k[\text{A}][\text{B}]^2$
- (2) $\text{Rate} = k[\text{A}]^2[\text{B}]^2$
- (3) $\text{Rate} = k[\text{A}][\text{B}]$
- (4) $\text{Rate} = k[\text{A}]^2[\text{B}]$

157. In which of the following reactions, standard reaction entropy change (ΔS°) is Positive and standard Gibbs energy change (ΔG°) decreases sharply with increasing temperature?

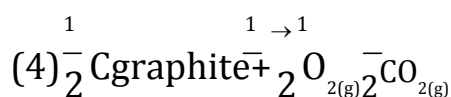
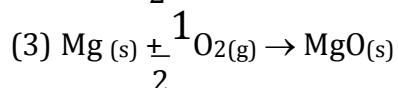
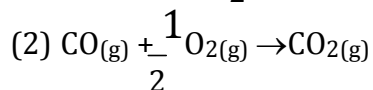
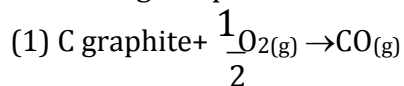

158. Which one of the following is a mineral of iron?

- (1) Malachite
- (2) Cassiterite
- (3) Pyrolusite
- (4) Magnetite

159. In Freundlich Adsorption isotherm, the value of $1/n$ is :

- (1) between 0 and 1 in all cases
- (2) between 2 and 4 in all cases
- (3) 1 in case of physical adsorption
- (4) 1 in case of chemisorption

160. Equimolar solutions of the following substances were prepared separately. Which one of these will record the highest pH value?

- (1) BaCl_2
- (2) AlCl_3
- (3) LiCl
- (4) BeCl_2

161. 50 mL of each gas A and of gas B takes 150 and 200 seconds respectively for effusing through a pin hole under the similar conditions. If molecular mass of gas B is 36, the molecular mass of gas A will be :

- (1) 96
- (2) 128
- (3) 32
- (4) 64

162. The correct set of four quantum numbers for the valence electron of rubidium atom ($Z=37$) is :

- (1) 5, 1, 1, $+\frac{1}{2}$
- (2) 6, 0, 0, $+\frac{1}{2}$
- (3) 5, 0, 0, $+\frac{1}{2}$
- (4) 5, 1, 0, $+\frac{1}{2}$

163. In which of the following compounds, nitrogen exhibits highest oxidation state?

- (1) N_2H_4
- (2) NH_3
- (3) N_3H
- (4) NH_2OH

164. Predict the product in the given reaction.

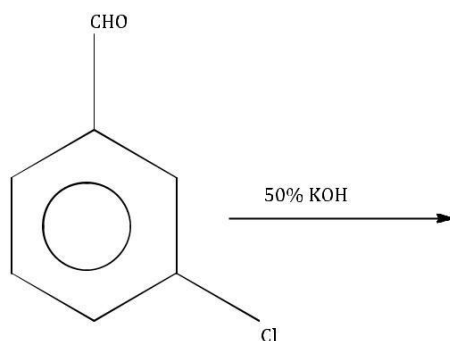

(1)

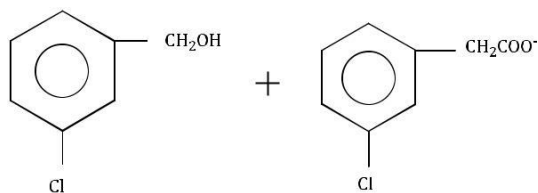

(2)

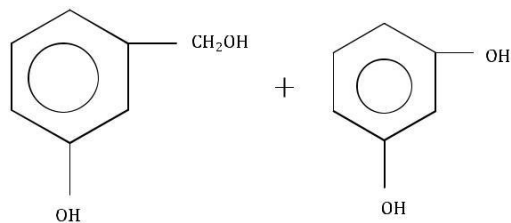

(3)

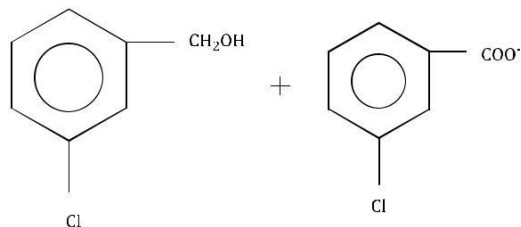

(4)

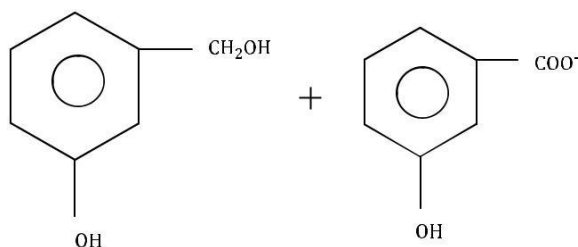

165. Acetone is treated with excess of ethanol in the presence of hydrochloric acid. The product obtained is :

(1)

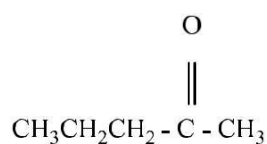

(2)

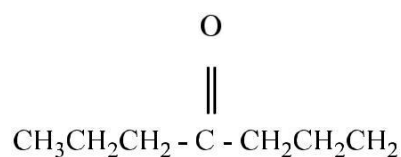

(3)

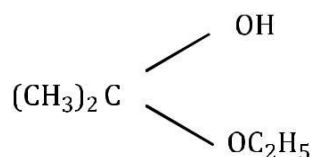

(4)

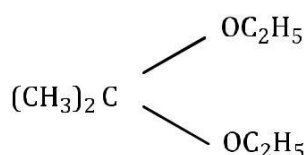

166. A metal crystallizes with a face-centered cubic lattice. The edge of the unit cell is 408 pm. The diameter of the metal atom is:

(1) 288 pm

(2) 408 pm

(3) 144 pm

(4) 204 pm

167. Which one of the following statements is incorrect about enzyme catalysis?

(1) Enzymes are mostly proteinous in nature

(2) Enzyme action is specific

(3) Enzymes are denaturated by ultraviolet rays and at high temperature

(4) Enzymes are least reactive at optimum temperature

168. In a zero- order reaction for every 10° rise of temperature, the rate is doubled. If the temperature is increased from 10°C to 100°C , the rate of the reaction will become :

- (1) 256 times
- (2) 512 times
- (3) 64 times
- (4) 128 times

169. Deficiency of vitamin B1 causes the disease

- (1) Convulsions
- (2) Beri-Beri
- (3) Cheilosis
- (4) Sterility

170. Among the following compounds the one that is most reactive towards electrophilic nitration is:

- (1) Benzoic Acid
- (2) Nitrobenzene
- (3) Toluene
- (4) Benzene

171. Buffer solutions have constant acidity and alkalinity because :

- (1) These give unionised acid or base on reaction with added acid or alkali.
- (2) Acids and alkalies in these solution are shielded from attack by other ions.
- (3) They have large excess of H^+ or OH^- ions.
- (4) They have fixed value of pH.

172. The correct order of decreasing acid strength of trichloroacetic acid (A), trifluoroacetic acid (B), acetic acid (C) and formic acid (D) is :

- (1) $\text{B} > \text{A} > \text{D} > \text{C}$
- (2) $\text{B} > \text{D} > \text{C} > \text{A}$
- (3) $\text{A} > \text{B} > \text{C} > \text{D}$
- (4) $\text{A} > \text{C} > \text{B} > \text{D}$

173. Which one of the following sets of monosaccharides forms sucrose?

- (1) α -D-Galactopyranose and α -D- fructofuranose
- (2) α -D-Glucopyranose and β -D-fructofuranose
- (3) β -D-Glucopyranose and α -D-fructofuranose
- (4) α -D-Glucopyranose and β -D-fructofuranose

174. The enthalpy of fusion of water is 1.435 kcal/mol. The molar entropy change for the melting of ice at 0°C is :

- (1) 10.52 cal / (mol K)
- (2) 21.04 cal / (mol K)
- (3) 5.260 cal / (mol K)
- (4) 0.526 cal / (mol K)

175. Which one of the following pairs is isostructural (i.e. having the same shape and hybridization)?

- (1) [BCl₃ and BrCl₃]
- (2) [NH₃ and NO₃⁻]
- (3) [NF₃ and BF₃]
- (4) [BF₄⁻ and NH₄⁺]

176. Bond order of 1.5 is shown by:

- (1) O₂⁺
- (2) O₂⁻
- (3) O₂²⁻
- (4) O₂

177. Which one of the following is not a condensation polymer?

- (1) Melamine
- (2) Glyptal
- (3) Dacron
- (4) Neoprene

178. In the following sequence of reactions

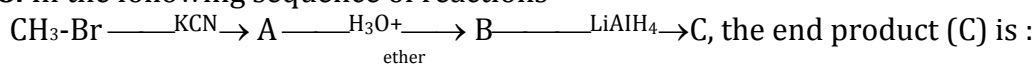

- (1) Acetone
- (2) Methane
- (3) Acetaldehyde
- (4) Ethyl alcohol

179. Which nomenclature is not according to IUPAC system?

- (1) Br - CH₂ - CH = CH₂, 1 - Bromo - prop -2 - ene
- (2)

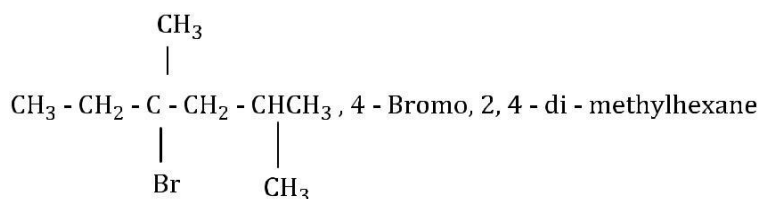

(3)

$\text{CH}_3 - \text{CH} - \text{CH} - \text{CH}_2 - \text{CH}_3$, 2 - Methyl - 3 - Phenylpentane

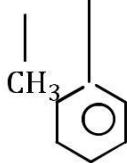

(4)

$\text{CH}_3 - \text{C} - \text{CH}_2 - \text{CH}_2 - \text{CH}_2\text{COOH}$ 5 - oxohexanoic acid



180. The number of octahedral void(s) per atom present in a cubic close-packed structure is:

- (1) 1
- (2) 3
- (3) 2
- (4) 4

181. In the extraction of copper from its sulphide ore, the metal is finally obtained by the reduction of cuprous oxide with :

- (1) Copper (I) sulphide (Cu_2S)
- (2) Sulphur dioxide (SO_2)
- (3) Iron sulphide (FeS)
- (4) Carbon monoxide (CO)

182. Identify the alloy containing a non-metal as a constituent in it.

- (1) Invar
- (2) Steel
- (3) Bell metal
- (4) Bronze

183. A mixture of potassium chlorate, oxalic acid and sulphuric acid is heated. During the reaction which element undergoes maximum change in the oxidation number ?

- (1) S
- (2) H
- (3) Cl
- (4) C

184. Which one of the alkali metals, forms only, the normal oxide, M_2O on heating in air?

- (1) Rb
- (2) K
- (3) Li
- (4) Na

185. The ease of adsorption of the hydrated alkali metal ions on an ion-exchange resins follows the order :

- (1) $Li^+ < K^+ < Na^+ < Rb^+$
- (2) $Rb^+ < K^+ < Na^+ < Li^+$
- (3) $K^+ < Na^+ < Rb^+ < Li^+$
- (4) $Na^+ < Li^+ < K^+ < Rb^+$

186. Which one of the following statements regarding photochemical smog is not correct?

- (1) Carbon monoxide does not play any role in photochemical smog formation
- (2) Photochemical smog is an oxidising agent in character
- (3) Photochemical smog is formed through photochemical reaction involving solar energy.
- (4) Photochemical smog does not cause irritation in eyes and throat.

187. CH_3CHO and $C_6H_5CH_2CHO$ can be distinguished chemically by :

- (1) Benedict test
- (2) Iodoform test
- (3) Tollen's reagent test
- (4) Fehling solution test

188. Which of the statements is **not** true?

- (1) On passing H_2S through acidified $K_2Cr_2O_7$ solution, a milky colour is observed
- (2) $Na_2Cr_2O_7$ is preferred over $K_2Cr_2O_7$ in volumetric analysis
- (3) $K_2Cr_2O_7$ solution in acidic medium is orange
- (4) $K_2Cr_2O_7$ solution becomes yellow on increasing the pH beyond 7

189. Standard enthalpy of vapourisation $\Delta_{vap} H^\circ$ for water at $100^\circ C$ is $40.66 \text{ kJ mol}^{-1}$.

The internal energy of vaporization of water at $100^\circ C$ (in kJmol^{-1}) is:

- (1) +37.56
- (2) -43.76
- (3) +43.76
- (4) +40.66

190. Identify the **wrong** statement in the following :

- (1) Amongst isoelectronic species, smaller the positive charge on the cation, smaller is the ionic radius.
- (2) Amongst isoelectronic species, greater the negative charge on the anion, larger is the ionic radius.
- (3) Atomic radius of the elements increases as one moves down the first group of the periodic table.
- (4) Atomic radius of the elements decreases as one moves across from left to right in the 2nd period of the periodic table.

191. Which of the following statements is not valid for oxoacids of phosphorus?

- (1) Orthophosphoric acid is used in the manufacture of triple superphosphate
- (2) Hypophosphorous acid is a diprotic acid
- (3) All oxoacids contain tetrahedral four coordinated phosphorus
- (4) All oxoacids contain atleast one P=O unit and one P-OH group

192. The protecting power of lyophilic colloidal sol is expressed in terms of :

- (1) Coagulation value
- (2) Gold number
- (3) Critical miscelle concentration
- (4) Oxidation number

193. Sulphur trioxide can be obtained by which of the following reaction:

- (1) $\text{CaSO}_4 + \text{C} \longrightarrow$
- (2) $\text{Fe}_2 (\text{SO}_4)_3 \longrightarrow$
- (3) $\text{S} + \text{H}_2\text{SO}_4 \longrightarrow$
- (4) $\text{H}_2\text{SO}_4 + \text{PCl}_5 \longrightarrow$

194. P_A and P_B are the vapour pressure of pure liquid components, A and B, respectively of an ideal binary solution. If X_A represents the mole fraction of component A, the total pressure of the solution will be.

- (1) $P_A + X_A (P_B - P_A)$
- (2) $P_A + X_A (P_A - P_B)$
- (3) $P_B + X_A (P_B - P_A)$
- (4) $P_B + X_A (P_A - P_B)$

195. Which of the following acids does not exhibit optical isomerism?

- (1) Maleic acid
- (2) α -amino acids
- (3) Lactic acid
- (4) Tartaric acid

196. Which of the following species contains three bond pairs and one lone pair around the central atom?

- (1) H₂O
- (2) BF₃
- (3) NH₂⁻
- (4) PCl₃

197. Limiting molar conductivity of NH₄OH is equal to:

- (1) $\Lambda_m(\text{NH}_4\text{Cl}) + \Lambda_m(\text{NaCl}) - \Lambda_m(\text{NaOH})$
- (2) $\Lambda_m(\text{NaOH}) + \Lambda_m(\text{NaCl}) - \Lambda_m(\text{NH}_4\text{Cl})$
- (3) $\Lambda_m(\text{NH}_4\text{OH}) + \Lambda_m(\text{NH}_4\text{Cl}) - \Lambda_m(\text{HCl})$

(4) $\Lambda_m(\text{NH}_4\text{Cl}) + \Lambda_m(\text{NaOH}) - \Lambda_m(\text{NaCl})$

198. The pair of species with the same bond order is :

- (1) O₂²⁻, B₂
- (2) O₂⁺, NO⁺
- (3) NO, CO
- (4) N₂, O₂

199. Which of the following statements is false?

- (1) Artificial silk is derived from cellulose.
- (2) Nylon-66 is an example of elastomer.
- (3) The repeat unit in natural rubber is isoprene.
- (4) Both starch and cellulose are polymers of glucose.

200. In the following reaction :

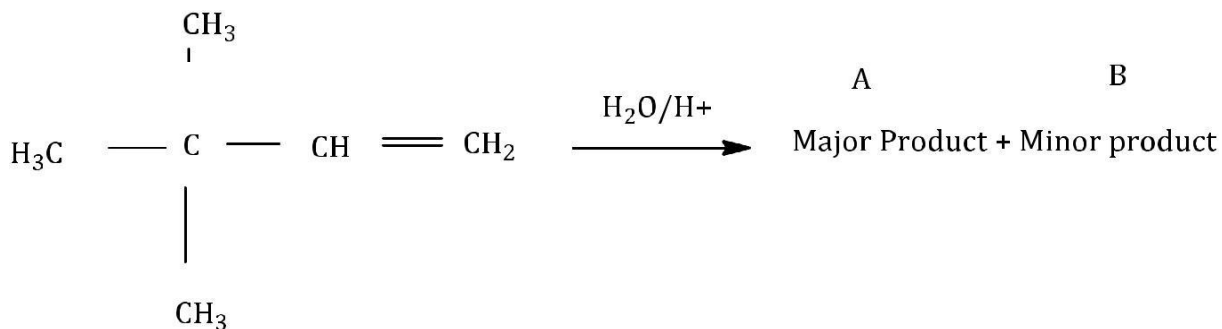

(1)

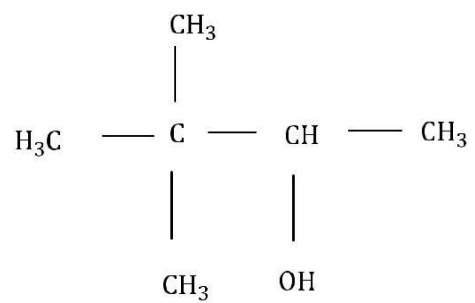

(2)

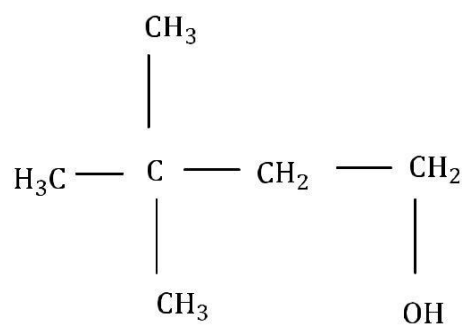

(3)

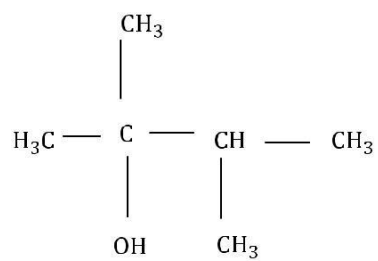

(4)

